

FACTORY APPLIED ANCHOR CLAMPS

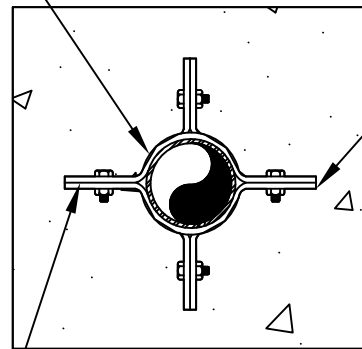

COPPER PLATED RISER CLAMPS AND BOLTS

INSTALLING CONTRACTOR TO COAT ALL EXPOSED COPPER IN MASTIC SEALANT BEFORE POURING CONCRETE THRUST BLOCK

SECTION A-A

N.T.S.

FACTORY APPLIED COPPER ANCHOR DETAIL

N.T.S.

Rovanco®

20535 S.E. FRONTAGE RD. JOLIET, IL. 60431 (815) 741-6700

NAME: FACTORY APPLIED COPPER ANCHOR DETAIL

APPR BY:
DK

DRAWN BY:
AD

DATE/REV:
10/26/2009

DWG NO:
FMP-CUXPV-A-01